

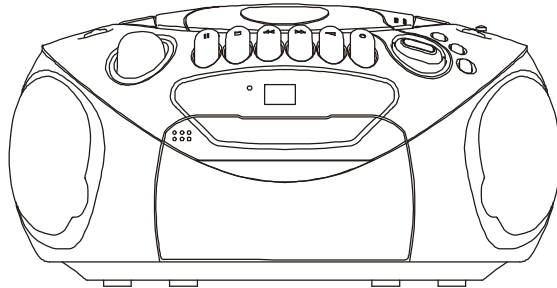

COBY®

CX-CD249

INSTRUCTION MANUAL







PORTABLE CD RADIO CASSETTE RECORDER

WARNING: To prevent fire or shock hazard, do not expose this appliance to rain or moisture. This equipment must be disconnected from the mains when not in use.

Dripping warning: The product shall not be exposed to dripping or splashing and that no objects filled with liquids, such as vases, shall be placed on the product.

Ventilation warning: The normal ventilation of the product shall not be impeded for intended use.

IMPORTANT INFORMATION

	CAUTION RISK OF ELECTRIC SHOCK DO NOT OPEN	
WARNING: TO PREVENT THE RISK OF FIRE OR ELECTRIC SHOCK, DO NOT EXPOSE THIS APPLIANCE TO RAIN OR MOISTURE.		
CAUTION: TO REDUCE THE RISK OF ELECTRIC SHOCK, DO NOT REMOVE COVER. NO USER SERVICEABLE PARTS INSIDE. REFER SERVICING TO QUALIFIED SERVICE PERSONNEL.		
	:This symbol indicates that dangerous voltage constituting a risk of electric shock is present within this unit.	
	:This symbol indicates that there are important operating and maintenance instructions in the literature accompanying this unit.	

- 1) Read these instructions carefully.
 - 2) Keep these instructions for future reference.
 - 3) Heed all warnings.
 - 4) Follow all instructions.
 - 5) Do not expose to water or moisture.
 - 6) Clean only with a dry cloth.
 - 7) Keep objects away from ventilation openings. Do not block any ventilation openings at any time.
 - 8) Do not install near any heat sources such as stoves, computer towers, amplifiers or any apparatus that produce heat.
 - 9) Do not force the power plug in the wall outlet. A polarized plug as two blades with one wider than the other. The wide blade is provided for your safety. If the provided plug does not fit into your outlet, consult an electrician for replacement of the obsolete outlet.
 - 10) Place the power cord so that it is protected from being walked on, pinched by objects, torn and exposed to liquids, especially at plugs, convenience receptacles, and the point where they exit from the product.
 - 11) Only use attachments/accessories specified by the manufacturer. Use of attachments/accessories not recommended by the product manufacturer may cause hazards.
 - 12) Use only with a cart, stand, tripod, bracket, or table specified by the manufacturer, or sold with the apparatus. When a cart is used, use caution when moving the cart/apparatus combination to avoid injury from tip-over.
 - 13) Unplug the apparatus during lightning storms or when unused for long periods of time.
 - 14) Do not use this apparatus near water, and no objects filled with liquids, such as vases, shall be placed on the apparatus.
 - 15) Refer all servicing to authorized service personnel.
- For recycling or disposal information about this product, please contact your local authorities or the Electronics Industries Alliance: www.eiae.org

LOCATION OF CONTROLS

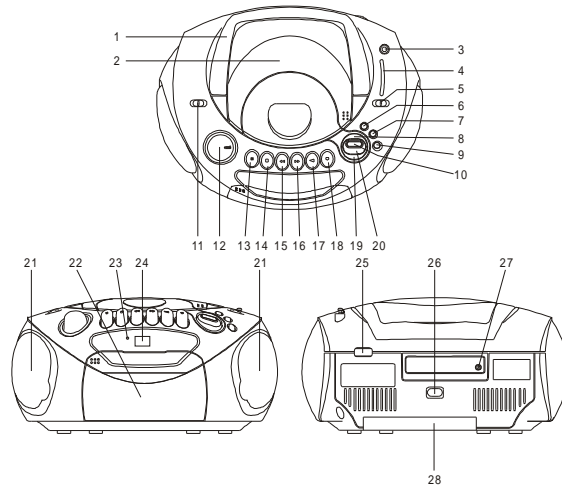

- | | |
|----------------------------------|--|
| 1. Handle | 15. Fast Forward Button (Tape) |
| 2. CD Compartment | 16. Rewind Button (Tape) |
| 3. Antenna | 17. Play Button (Tape) |
| 4. Tuning Indicator | 18. Record Button (Tape) |
| 5. Band Switch | 19. Previous/Fast Backward Button (CD) |
| 6. Repeat Button (CD) | 20. Stop Button (CD) |
| 7. Random Button (CD) | 21. Speaker |
| 8. Next/Fast Forward Button (CD) | 22. Cassette Door |
| 9. Program Button (CD) | 23. FM Stereo Indicator |
| 10. Play/Pause Button (CD) | 24. LED Display |
| 11. Function Switch | 25. Tuning Dial |
| 12. Volume Knob | 26. AC Socket |
| 13. Pause Button (Tape) | 27. Headphone Jack |
| 14. Stop/Eject Button (Tape) | 28. Battery Compartment |

2

POWER SUPPLY AND CONNECTION

Battery Operation

- Remove the battery compartment cover.
- Insert 8 x "C" batteries (UM-2 or equivalent) with the correct polarity as indicated inside the compartment.
- Replace the cover.

Note: Check your batteries regularly, old or dead batteries should be replaced. If the unit is not going to be used for a long time or is being run exclusively on AC power, remove the batteries to avoid leakage and damage.

To remove batteries from the compartment, open the cover and simply shake the unit gently.

AC Operation

Take the supplied AC power cord and connect the corresponding ends to the AC socket and the household outlet. Make sure the voltage is compatible.

Note: If you unplug the AC power cord from the AC socket or from the unit, the unit will operate from DC power.

RADIO OPERATION

Operation

- Set the Function Switch to the "RADIO" position.
- Select the desired radio frequency band with the Band Switch.
- Rotate the Tuning Dial to set the Tuning Indicator to the station frequency as marked on the tuning scale.
- Adjust the Volume Knob to the desired level. To turn off the radio, set the Function Switch to the "TAPE" position without the Play Button pressed.

3



Antenna

For FM stations, extend the Telescopic Antenna to full length, adjust the angle and direction for the best reception. You may have to orientate the set to obtain the clearest reception.

CASSETTE RECORDER OPERATION

- **Stop/Eject Button:** During operation, press to stop all deck operation. Press again to open the Cassette Door.
- **Fast Forward Button/Rewind Button:** Press to fast forward or rewind.
- **Play Button:** Press to start playback.
- **Pause Button:** Press to stop tape operation temporarily. Press again to resume the tape operation.
- **Record Button:** Press together with Play Key to start recording.

Insertion and Removal of Cassette

- Press the Stop/Eject Button to open the Cassette Door.
- Put your cassette tape in the holder with the exposed section facing up and the playback side facing you.
- Close the Cassette Door securely before starting. When finished, press Stop/Eject Key to open the holder and retrieve your cassette.

Note: Before inserting a cassette, take up any slack tape by turning the tape spool. If the spool feels tight, this could be due to ridges formed in the tape. This can usually be overcome by fast winding the cassette to the end and back again. Use only well known brands of tape and avoid the use of C120's. Do not expose cassettes to direct sunlight, dust or oil.

Playback

- Set the Function Switch to the "TAPE" position.
- Insert a cassette tape.
- Press the Play Button to start playback.
- Adjust the Volume Knob to the appropriate level as desired.
- Press the Stop/Eject Button when finished.

Recording

A. Recording from the Radio

- Set the Function Switch to the "RADIO" position and tune to the desired station.
- Insert a cassette tape.
- Press both the Play Button and the Record Button together to start recording.
- Press the Stop/Eject Button when finished.



B. Recording from a CD

- Set the Function Switch to the "CD" position.
- Put a disc into the CD compartment, then close the compartment.
- Press the Play Button to start playing the CD.
- Press both the Play Button and Record Button together to start recording.
- Press the Stop/Eject Button when finished.

PLAYING A COMPACT DISC

Getting Started

1. Set the Function Switch to the "CD" position. Put a disc into the compartment then close the door.
2. The display will show the total number of tracks on the disc.
3. Do not swing or shock the unit when playing CD, otherwise it may not function properly.



General Operation

Play/Pause Button

Press once to start playback. The indicator on the right will turn on. Press again to stop playing the disc temporarily. The indicator on the right will flash. Press once more to resume playback.

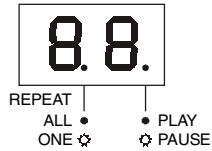

Stop Button

Press to stop playback. The total number of tracks will be shown.

Next/Fast Forward Button

Press and release to go to the next track. Press and hold to fast forward the current track.

Previous/Fast Backward Button

Press and release to go back to the beginning of the current track. Press twice to go back to the previous track. Press and hold to fast backward the current track.

Repeat 1

Press the Repeat Button once, the track number shown will be repeated. The indicator on the left will flash.

Repeat All

Press the Repeat Button twice, all tracks will be repeated. The indicator on the left will turn on. Press again to resume normal playback. The indicator on the left will turn off.

Program Button

In the stop mode, press the Program Button, the track number on the display will flash. Use the Next/Previous Buttons to choose the tracks you wish to program, then press the Program Button again to finish the first track programming.

Repeat the above steps to program more tracks. Maximum of 20 tracks can be programmed. Press the Play Button to start, the tracks will play in the programmed order.

To clear the program memory, press the Stop Button.

SPECIAL FEATURES

Auto Stop

When the end of the tape is reached while playing or recording, the motor is switched off and the buttons released. This feature does not work for "Rewind" or "Fast Forward", and the Stop Button must be pressed when the cassette spools (visible through the window) stop turning.

Automatic Level Control (ALC)

This unit has built-in ALC circuitry, which automatically adjusts the optimum recording level.

MAINTENANCE & CARE

1. Check your batteries regularly, old or dead batteries should be replaced. If the unit is not going to be used for a long time or is being run exclusively on AC power, remove the batteries to avoid leakage and damage.
2. Electronic products of this kind should never be subjected to extreme temperatures or high humidity to ensure normal functioning and a long life-time. For instance, this set should not be placed in bathing areas, nor close to stoves and radiators.
3. If necessary, clean the unit with a piece of cloth dampened with water only. (Be sure the AC Power Cord is disconnected from the outlet.) Never use a polish nor a strong detergent as this will damage the finish of the cabinet.
4. The heads and capstan are in constant contact with the moving tape. If dirt or dust adheres to them, deterioration of performance, such as sound decrease, distortion or fluctuation will result. Use a small cotton bud with alcohol or special tape head cleaner to clean these parts. Never touch the heads with anything Metallic.

Prop. 65 Warning: Handling the coated electrical wires of this product exposes you to lead, a chemical known to the State of California to cause cancer, birth defects and other reproductive harm. **Wash hands after use.**